

**Product Cat. No.: FP-054.**

**CE-IVD Registration No.: DE/CA20/IVD-Luxuslebenswelt-22/20.**

## MDM2 Gene Amplification Probe Detection Kit

**[Product Name]** MDM2 Gene Amplification Probe Detection Kit (Fluorescence In Situ Hybridization Method).

**[Product Introduction]**

This kit uses Orange fluorescein labeled MDM2 probe and Green fluorescein labeled CEP12, to combine MDM2/CEP12 genes with the target site by in situ hybridization.

**[Product Main Components]**

The kit consists of MDM2/CEP12 dual color probe as shown in Table 1.

**Table 1 Kit composition**

Component name	Specifications	Quantity	Main components
MDM2/CEP12 dual color probe	100µl/Tube	1	MDM2 orange probe CEP12 green probe

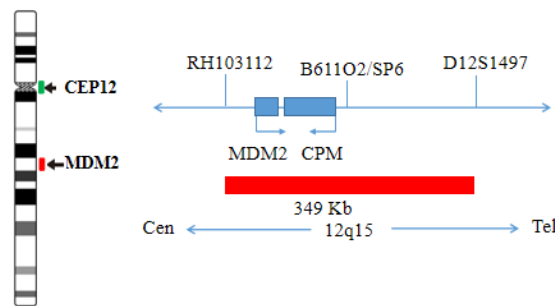

**[Storage conditions & Validity]**

Keep sealed away from light at  $-20^{\circ}\text{C} \pm 5^{\circ}\text{C}$ . The product is valid for 12 months. Avoid unnecessary repeated freezing and thawing that should not exceed 10 times. After opening, within 24 hours for short-term preservation, keep sealed at  $2-8^{\circ}\text{C}$  in dark. For long-term preservation after opening, keep the lid sealed at  $-20^{\circ}\text{C} \pm 5^{\circ}\text{C}$  away from light.

**[Applicable Instruments]**

Fluorescence microscopy imaging systems, including fluorescence microscopy and filter sets suitable for DAPI (367/452), Green (495/517), and Orange (547/565).

**[Sample requirements]**

1. Applicable specimen types: Paraffin-embedded specimens for surgical resection or biopsy.
2. Tissue should be fixed with 4% neutral formaldehyde fixation solution within 1 hour after ex vivo, and the tissue should be fixed by conventional dehydration and paraffin embedding.

**[Instructions]**

**1. Pre-hybridization or Pretreatment**

It is recommended to use Wuhan HealthCare Biotechnology Co., Ltd.'s "FISH Pretreatment Reagent Kit" (Cat# CL-003) for pretreatment.

**2. Denaturation and Hybridization**

The following operations need to be carried out in the darkroom.

- ① Take out the probe, leave it at room temperature for 5min, turn it upside down with force, mix it well, and then centrifuge it for a short time (no vortex instrument vibration). Take 10µL of it and drop it into the cell drop hybridization area, immediately cover the

cover glass of 22mm × 22mm. The probe should be evenly expanded under the cover glass without bubbles, and seal the edge with rubber glue (the edge must be completely sealed to prevent the dry piece from affecting the test results in the hybridization process).

② The cell drops were placed on the hybridizer and denatured at 85°C for 5 min (the hybridizer should be preheated to 85°C) and hybridized at 42°C for 2-16 hours.

### 3. Washing

The following operations need to be carried out in the darkroom.

① Carefully remove the sealing glue around the cover glass with tweezers to avoid sticking or moving the cover glass, immerse the sample in 2xSSC for about 5S, take it out, gently push a corner of the cover glass to the edge of the slide with tweezers, and gently remove the cover glass with tweezers;

② Place the sample at 2xSSC room temperature for 1 min;

③ Take out the sample and immerse it in 0.3%NP-40/0.4xSSC solution preheated at 68°C for 2min;

④ Take out the sample and immerse it in deionized water preheated at 37°C in advance for 1min; dry it naturally in the dark place.



### 4. Dyeing

The following operations should be performed in a darkroom

10μl DAPI compound dye is dropped in the hybridization area of the glass slide and immediately covered. The suitable filter is selected for glass slide observation under the fluorescence microscope.

### 5. FISH results observation

Place the stained sections under a fluorescence microscope and the cells area is first confirmed under a low magnification objective (10×); under magnification objective (40×) a uniform cells distribution is observed; then the nucleus size uniformity, nuclear boundary integrity, DAPI staining uniformity, no nuclei overlapping, cells clear signal are observed in the high magnification objective (60x, 100x).

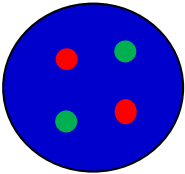
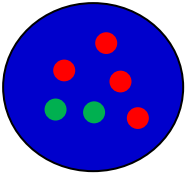
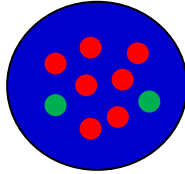
 MDM2 signal  CEP12 signal	
	Negative: 2 Orange ; 2 Green
	Positive: n Orange ; 2 Green (n≥4)
	

### [Precautions]

1. The results of this kit will be affected by various factors of the sample itself, as well as restrictions such as enzyme digestion time, hybridization temperature and time, operating environment, and limitations of current molecular biology techniques, which may result in erroneous interpretation results.

2. User must understand the potential errors and accuracy limitations that may exist during the testing process.

**[Manuscript version and approval date]**

Manual version: V1.0

Approval date: 03 September 2018